

Another Nested Models - Testing tau equivalence

Example testing tau equivalence of Self-Esteem from Project EAT (see model on next page)

- H_0 : Tau-equivalent model vs H_A : Congeneric model
- $H_0: 1 = a_{1_1} = a_{2_1} = a_{3_1} = a_{4_1} = a_{5_1}$
vs H_A : all factor loadings can be different
- Chi-square test value for Congeneric model = 238.5 with 9 degrees of freedom
- Chi-square test value for Tau-equivalent model = 263.8 with 14 degrees of freedom
- Chi-square difference test for hypothesis above = $263.8 - 238.5 = 25.3$
with $14 - 9 = 5$ d.f.
- The p-value associated with this test is $< .0001$, so we reject the Null hypothesis in favor of the alternative.
- Thus the Tau-equivalent model (more restrictive model) does not fit as well as the Congeneric model (less restrictive model).
- NOTE: This does not mean the Congeneric model fits well, for this we should consider how it compares to the saturated model or look at other Goodness of Fit tests.

Nested Models - Self esteem Project EAT

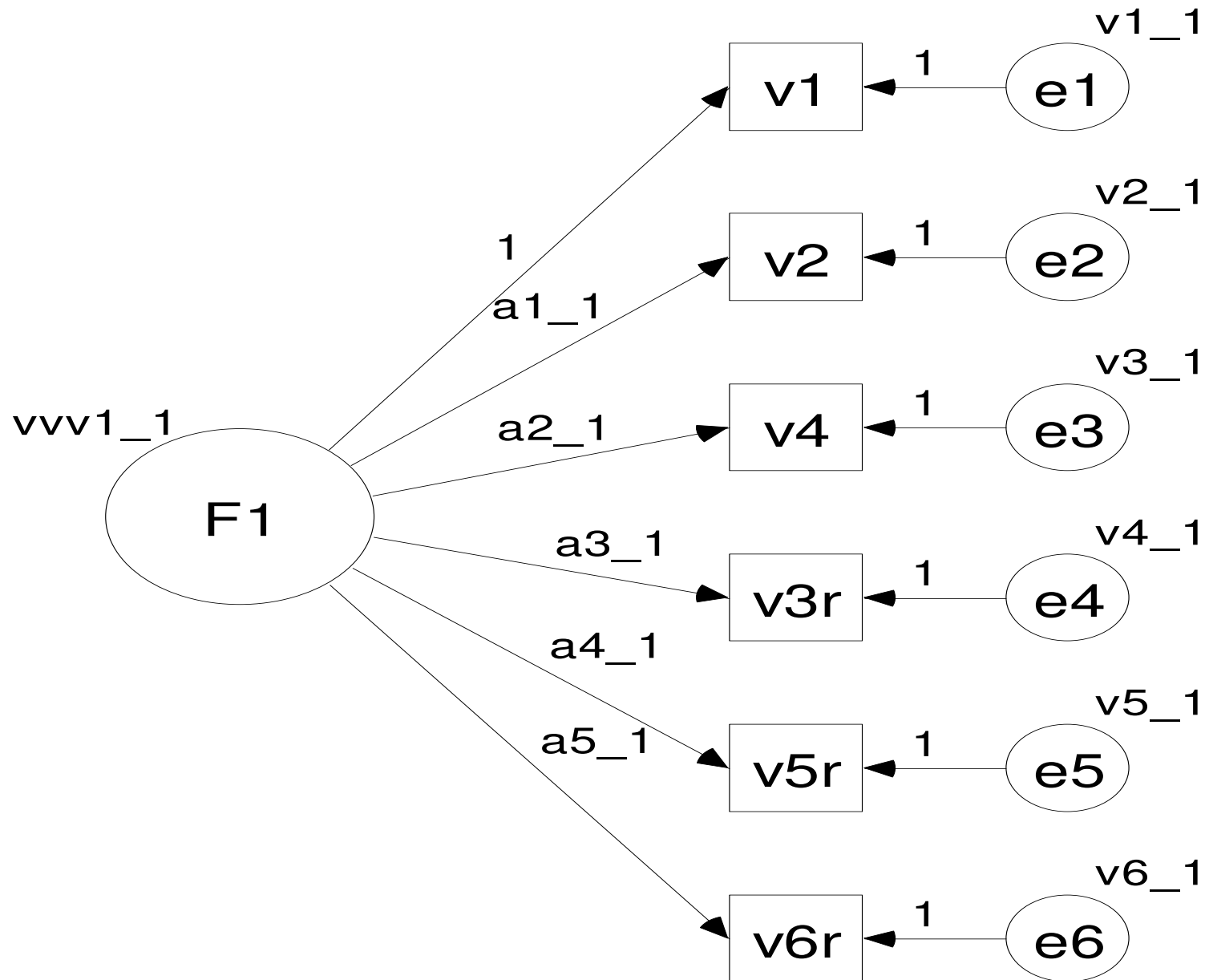

Note about Cronbach alpha under tau-equivalence

Modification Indices - Self esteem Project EAT

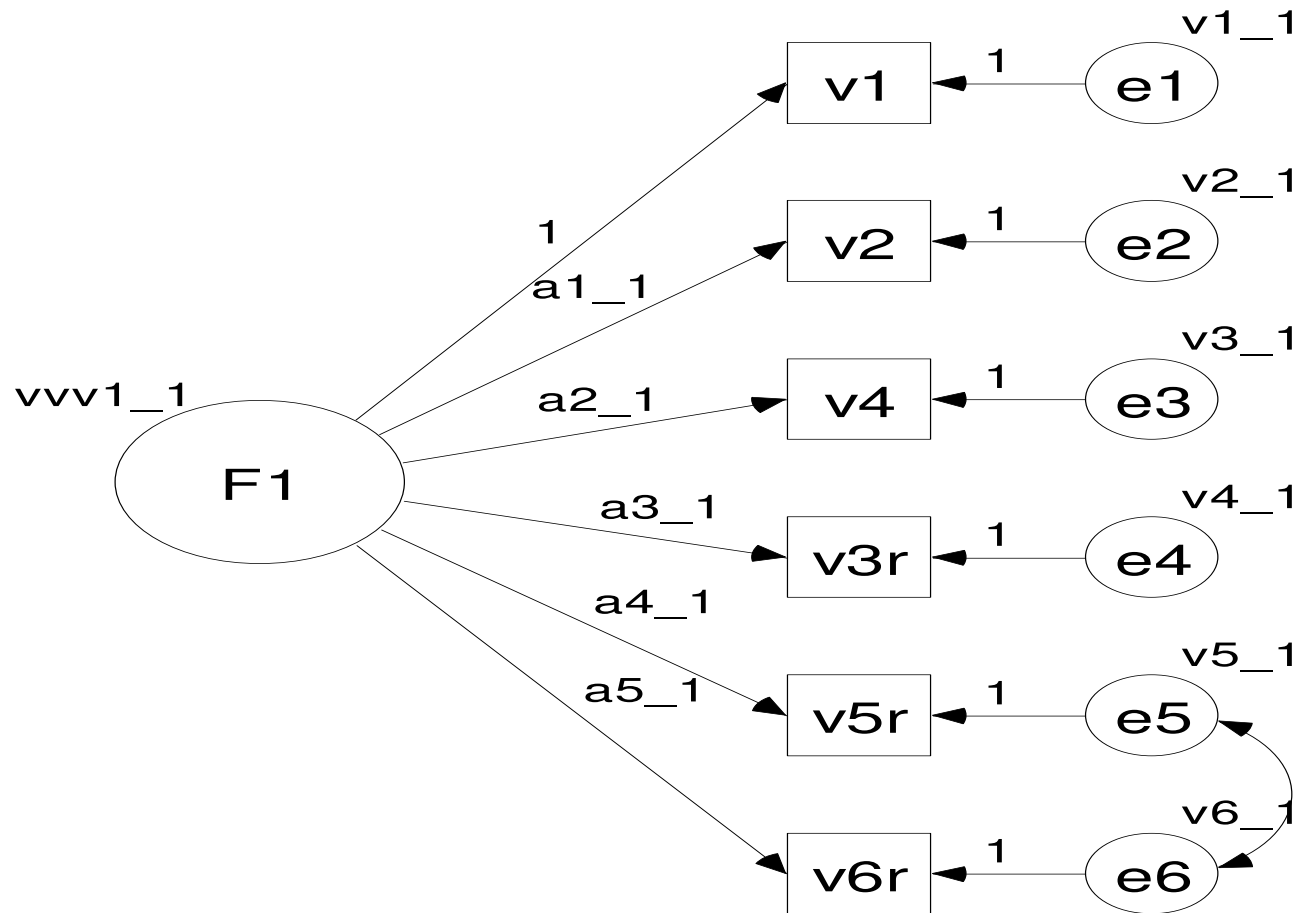

One of the Modification indices will test

H_0 : Model with $Corr(e5, e6) = 0$ (more restrictive since correlation forced to zero)

H_A : Model with $Corr(e5, e6) \neq 0$ (less restrictive since correlation is not fixed)

Modification Indices - Self esteem Project EAT

H_0 : Model with $Corr(e5, e6) = 0$ (more restrictive since correlation forced to zero)

H_A : Model with $Corr(e5, e6) \neq 0$ (less restrictive since correlation is not fixed)

The test is a chi-square difference test because the models are nested. That is, one model is just a restricted version of the other. So,

$$\chi^2_{\text{model w/o correlation}} - \chi^2_{\text{model with correlation}} = 238.5 - 129.9 = 108.6$$

and we compare this to a χ^2 distribution with $9 - 8 = 1$ d.f. This gives a p-value $< .0001$ suggesting we should reject the null in favor of the alternative suggesting that this added correlation greatly improves the model.

Actual value given for modification index is different in AMOS and Mplus each is using a different approximation since it too computationally intensive to refit model over and over dropping each restriction. Mplus claims their approximation is a lower bound.

Factor score estimation - Overview

- Once the number of factors and factor structure are identified, researcher often wants to create a score, a **factor score estimate** to represent each factor, which then can be used in subsequent analysis.
- If a common factor model is assumed then we will create a factor score estimate of the true underlying factors... It should be emphasized that this score is an error-prone measurement of the latent variable, i.e.

$$\hat{f}_i = f_i + \delta_i$$

That is, the score is expected to contain measurement error, although we would expect it to be more reliable than any one of the measures that went into it.

- NOTE: Individual level data is required (not just correlation matrix) in order to get scores for each individual.
- It should also be noted that an alternative approach to creating a factor score estimate is to explicitly model the latent variables in subsequent analysis as will be done in structural equation modeling.

Calculating factor score estimates - Simple sum score

The most common method used in all different literatures is to create a simple (equally weighted) sum score of items which load significantly on a particular factor

- Since this method does not take into account varying factor loading, it would not be expected to be most efficient method
- Turning that argument around, it can also be claimed that since the factor loadings are likely sample specific, we should not rely on them too much when making the score so that the score is more generalizable
- Use Cronbach's alpha to estimate reliability, recall it assumes $x_{ij} = f_i + \epsilon_{ij}$ that all loadings are equal (i.e. $\lambda_j = 1$ for all j). Raykov (1997-2001) shows Cronbach's alpha is a lower bound for actual reliability of "congeneric" measures, i.e. measures where the factor loadings are not all the same.
- Another argument in favor of this technique is that each score only includes items which significantly loaded on that factor

Calculating factor score estimates - Regression weights

- If we assume \mathbf{f} is normally distributed and $\mathbf{x}|\mathbf{f}$ is distributed normally, then

$$\begin{pmatrix} \mathbf{x} \\ \mathbf{f} \end{pmatrix} \sim N \left(\begin{pmatrix} \boldsymbol{\mu} \\ \mathbf{0} \end{pmatrix}, \begin{pmatrix} \boldsymbol{\Lambda}\boldsymbol{\Phi}\boldsymbol{\Lambda}' + \boldsymbol{\Psi} & \boldsymbol{\Phi}\boldsymbol{\Lambda}' \\ \boldsymbol{\Lambda}\boldsymbol{\Phi} & \boldsymbol{\Phi} \end{pmatrix} \right)$$

thus the best predictor of the underlying factor given the model is correct is

$$E(\mathbf{f}|\mathbf{x}) = \boldsymbol{\Phi}\boldsymbol{\Lambda}'(\boldsymbol{\Lambda}\boldsymbol{\Phi}\boldsymbol{\Lambda}' + \boldsymbol{\Psi})^{-1}(\mathbf{x} - \boldsymbol{\mu})$$

and so the factor score estimate is

$$\hat{f}_i = \hat{\boldsymbol{\Phi}}\hat{\boldsymbol{\Lambda}}'(\hat{\boldsymbol{\Lambda}}\hat{\boldsymbol{\Phi}}\hat{\boldsymbol{\Lambda}}' + \hat{\boldsymbol{\Psi}})^{-1}(\mathbf{x}_i - \hat{\boldsymbol{\mu}})$$

or sometimes it is calculated slightly different as

$$\hat{f}_i = \hat{\boldsymbol{\Phi}}\hat{\boldsymbol{\Lambda}}'\mathbf{S}^{-1}(\mathbf{x}_i - \hat{\boldsymbol{\mu}})$$

In general each factor score depends on all p observed variables. Also, in general, $Corr(\hat{f}_m, \hat{f}_{m'}) \neq Corr(f_m, f_{m'})$.

The square of the estimated correlation between $\hat{\mathbf{f}}$ and \mathbf{f} can be used as an estimate of reliability

Calculating factor score estimates - Bartlett; Anderson and Rubin

Make no assumption about the distribution of the underlying factors, in fact, treat them as fixed unknown quantities, then given estimates $\hat{\boldsymbol{\mu}}$, $\hat{\boldsymbol{\Lambda}}$ and $\hat{\boldsymbol{\Psi}}$ we can consider

$$\mathbf{x}_i = \hat{\boldsymbol{\mu}} + \hat{\boldsymbol{\Lambda}}\mathbf{f}_i + \boldsymbol{\epsilon}$$

with $\widehat{Var}(\boldsymbol{\epsilon}) = \hat{\boldsymbol{\Psi}}$ to be a regression model with \mathbf{f}_i as the q unknown parameter and $\hat{\boldsymbol{\Lambda}}$ as the observed regressors matrix. Thus the generalized least squares estimator is (Bartlett factor score):

$$\hat{f}_i = (\hat{\boldsymbol{\Lambda}}' \hat{\boldsymbol{\Psi}}^{-1} \hat{\boldsymbol{\Lambda}})^{-1} \hat{\boldsymbol{\Lambda}}' \hat{\boldsymbol{\Psi}}^{-1} (\mathbf{x}_i - \hat{\boldsymbol{\mu}})$$

Anderson and Rubin, 1956 is a modification of the Bartlett method so that $Corr(\hat{f}_m, \hat{f}_{m'}) = \mathbf{I}$

- Bartlett (1937) The statistical conception of mental factors. *British Journal of Psychology*, **28**, 97-104.
- Anderson, TW and Rubin, H. (1956) Statistical inference in factor analysis. *Proceedings of the third Berkley Symposium on Mathematical Statistics and Probability*, vol 5, pp 111-150.

Factor scores

How to get estimated factor scores out of AMOS and Mplus:

Measuring latent factors with categorical observed variables

This has been called

- Item response theory
- Factor analysis for categorical data
- Latent trait modeling

There are basically two general approaches which can be considered if we want to take into account the categorical nature of the observed variables

- Underlying response variable approach
- Response function approach (item response theory approach)

The difference in these two approaches boils down to where the categorical nature of the observed data is taken into account.

Underlying variable approach

Assumes that underlying each of the categorically observed variables x_j is a continuous variable x_j^* which is actually measuring the ultimate underlying latent factors \mathbf{f} , but we were only able to “partially observe” it through x_j .

We assume the traditional linear factor analysis model for the “partially observed” variables \mathbf{x}_j^* , i.e.

$$\mathbf{x}^* = \boldsymbol{\mu} + \boldsymbol{\Lambda}\mathbf{f} + \boldsymbol{\epsilon}$$

and we assume that for $x_j = s$, with $s = 0, 1, \dots, m_j$ that

$$x_j = \begin{cases} 1 & \text{if } -\infty < x_j^* \leq \tau_{j(1)} \\ 2 & \text{if } \tau_{j(1)} < x_j^* < \tau_{j(2)} \\ \vdots & \\ s & \text{if } \tau_{j(s-1)} < x_j^* < \tau_{j(s)} \\ \vdots & \\ m_j & \text{if } \tau_{j(m_j-1)} < x_j^* < \infty \end{cases}$$

with $-\infty < x_j^* < \tau_{j(1)} < \tau_{j(1)} < \dots < \tau_{j(m_j-1)} < \infty$ are parameters called threshold values.

Underlying variable approach

Since only ordinal information is available about x_j^* , the mean and variance of it are not identified and are therefore set to zero and one, respectively. It is assumed that $\mathbf{f} \sim N(\mathbf{0}, \mathbf{I})$ and $\epsilon \sim N(\mathbf{0}, \text{diag}(\Psi))$.

Several methods for fitting this model:

- underlying multivariate normality technique (requires p dimensional integral)
- underlying bivariate normality technique (single step uses only bivariate distributions)
- three step approach
 - Method implemented in LISREL and MPLUS
 - first step: estimate thresholds based on univariate distributions
 - second step: estimate correlation of \mathbf{x}^* using polychoric correlations. Note if two variables are dichotomous, it is called tetrachoric correlation.
 - Use the polychoric correlations as input into a usual factor analysis routine

Limited information techniques (except for the multivariate normality technique) because they are only based on univariate and bivariate moments. For categorical data, the first and second moments are not sufficient statistics for the entire distribution.

Polychoric correlation - How does it work Draw picture

Pearson correlation for categorical - How bad is it?

From Muthen Muthen Mplus shortcourse

Correlational Attenuation

Correlation between underlying continuous y^* variables = 0.5

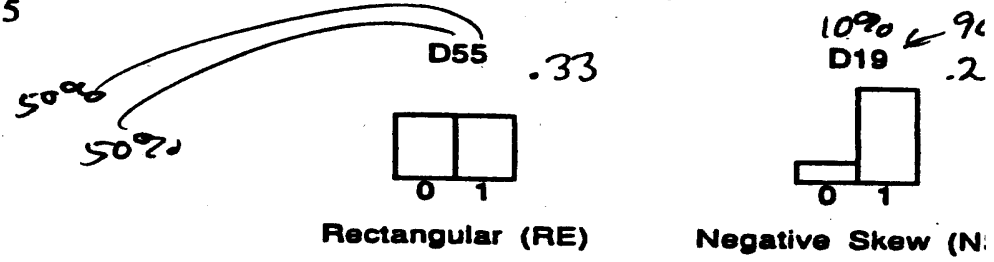

Three Categories

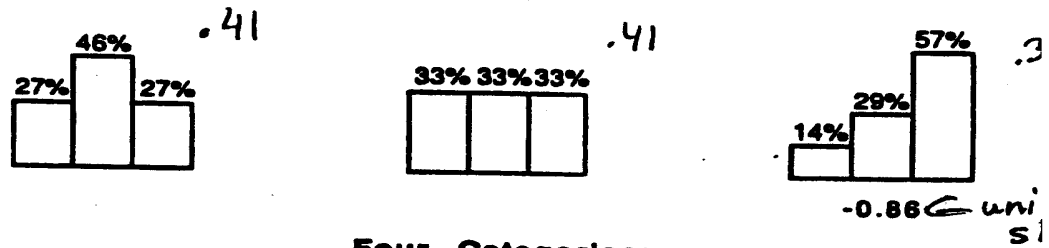

Four Categories:

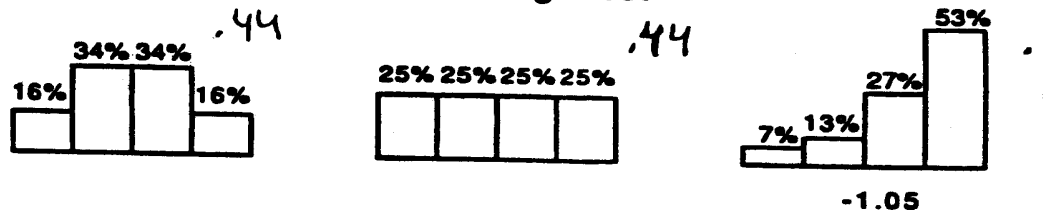

Five Categories

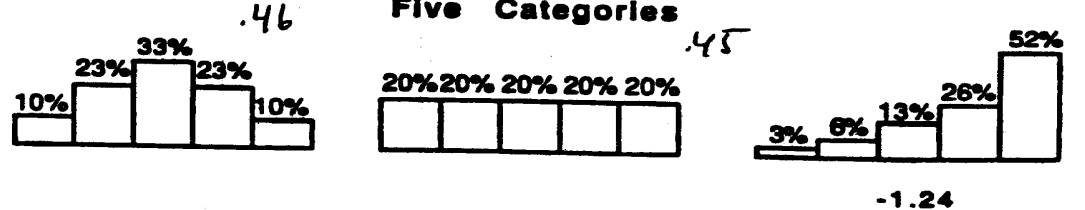

Pearson correlation for categorical - How bad is it?

From Muthen Muthen Mplus shortcourse

Table 1 (Part 2)
Pearson Correlations for True Correlations = 0.50

| | D19 | D28 | D37 | D46 | D55 | D64 | D73 | D82 | D91 | 3SY | 3RE | 3NS | 3PS |
|-----|-----|-----|-----|-----|-----|-----|-----|-----|-----|-----|-----|-----|-----|
| D19 | 25 | | | | | | | | | | | | |
| D28 | 26 | 30 | | | | | | | | | | | |
| D37 | 26 | 30 | 32 | | | | | | | | | | |
| D46 | 24 | 30 | 32 | 33 | | | | | | | | | |
| D55 | 23 | 28 | 31 | 33 | 33 | | | | | | | | |
| D64 | 20 | 26 | 30 | 23 | 33 | 33 | | | | | | | |
| D73 | 18 | 23 | 27 | 30 | 31 | 32 | 32 | | | | | | |
| D82 | 15 | 20 | 23 | 26 | 28 | 30 | 30 | 30 | | | | | |
| D91 | 10 | 15 | 18 | 20 | 22 | 24 | 26 | 26 | 25 | | | | |
| 3SY | 26 | 32 | 35 | 36 | 37 | 36 | 35 | 32 | 26 | 41 | | | |
| 3RE | 25 | 31 | 35 | 36 | 37 | 36 | 35 | 31 | 25 | 41 | 41 | | |
| 3NS | 29 | 33 | 35 | 36 | 35 | 33 | 30 | 26 | 20 | 39 | 39 | 39 | |
| 3PS | 20 | 26 | 30 | 33 | 35 | 36 | 35 | 33 | 29 | 39 | 39 | 34 | 39 |
| 4SY | 27 | 33 | 36 | 38 | 38 | 38 | 36 | 33 | 27 | 43 | 43 | 40 | 40 |
| 4RE | 26 | 33 | 36 | 38 | 38 | 38 | 36 | 33 | 26 | 42 | 42 | 40 | 40 |
| 4NS | 30 | 35 | 36 | 36 | 35 | 33 | 30 | 27 | 20 | 40 | 39 | 40 | 34 |
| 4PS | 20 | 27 | 31 | 34 | 35 | 36 | 36 | 35 | 30 | 40 | 39 | 34 | 40 |
| 5SY | 28 | 34 | 37 | 38 | 39 | 38 | 37 | 34 | 28 | 44 | 43 | 41 | 41 |
| 5RE | 27 | 33 | 37 | 38 | 39 | 38 | 37 | 33 | 27 | 43 | 43 | 41 | 41 |
| 5NS | 31 | 35 | 36 | 36 | 35 | 33 | 30 | 26 | 20 | 40 | 39 | 40 | 34 |
| 5PS | 20 | 26 | 30 | 33 | 35 | 36 | 36 | 35 | 31 | 40 | 39 | 34 | 40 |
| CCN | 29 | 35 | 38 | 39 | 40 | 39 | 38 | 35 | 29 | 45 | 45 | 42 | 42 |
| | D19 | D28 | D37 | D46 | D55 | D64 | D73 | D82 | D91 | 3SY | 3RE | 3NS | 3PS |

Pearson Correlations for True Correlations = .50

| | 4SY | 4RE | 4NS | 4PS | 5SY | 5RE | 5NS | 5PS | CCN |
|-----|-----|-----|-----|-----|-----|-----|-----|-----|-----|
| 4SY | 44 | | | | | | | | |
| 4RE | 44 | 44 | | | | | | | |
| 4NS | 41 | 41 | 41 | | | | | | |
| 4PS | 41 | 41 | 35 | 41 | | | | | |
| 5SY | 45 | 45 | 42 | 42 | 46 | | | | |
| 5RE | 45 | 45 | 41 | 41 | 46 | 45 | | | |
| 5NS | 41 | 40 | 42 | 34 | 42 | 41 | 42 | | |
| 5PS | 41 | 41 | 34 | 42 | 42 | 41 | 34 | 42 | |
| CCN | 47 | 46 | 43 | 43 | 48 | 47 | 44 | 44 | 50 |
| | 4SY | 4RE | 4NS | 4PS | 5SY | 5RE | 5NS | 5PS | CCN |

Alcoholism example

Questionnaire fill out by patients presenting for alcoholism treatment. Part of a large assessment/evaluation study to examine the impact of alcoholism treatment on health related outcomes. The present data are made up of 8227 individuals (34.2% are female) all are over 18 yrs old (average age 37).

| | | |
|----------|---|-------|
| hangover | Had hangover/headach (past 6 months) | 56.10 |
| nausea | Had nausea/vomiting (past 6 months) | 32.79 |
| sweats | Had sweats (past 6 months) | 30.59 |
| seizures | Had seizures (past 6 months) | 2.80 |
| cravings | Had cravings (past 6 months) | 48.24 |
| passout | Passed out (past 6 months) | 24.12 |
| blackout | Blacked out (past 6 months) | 41.91 |
| shakes | Had shakes/tremors (past 6 months) | 30.67 |
| sleeping | Had trouble sleeping (past 6 months) | 46.71 |
| dts | Had the DTs (past 6 months) | 2.77 |
| halluc | Had hallucinations (past 6 months) | 6.82 |
| othsym | Other physical symptoms (past 6 months) | 5.35 |

There are $2^{12} = 4096$ possible response profiles. From these 8227 individuals there were only a total of 794 different response profiles given. 18.1% of individuals said no to all 12 items. Some examples of other response profiles are: 3.8% who said yes only to the hangover question, 2.1% who said yes to everything except seizures, dts and halluc, 1.9% said yes to just trouble sleeping and cravings.

Input for Mplus

DATA:

```
FILE IS "C:\Mplus\ph5482\niaaa_no_column_label";
```

```
VARIABLE: NAMES ARE sex age pmotiv new_id hangover nausea sweats  
seizures cravings passout blackout shakes sleeping dts halluc  
othsym imprel job legal health abstine control ;
```

```
USEVARIABLES ARE HANGOVER NAUSEA SWEATS SEIZURES CRAVINGS PASSOUT  
BLACKOUT SHAKES SLEEPING DTS HALLUC OTHSYM;
```

```
categorical ARE HANGOVER NAUSEA SWEATS SEIZURES CRAVINGS PASSOUT  
BLACKOUT SHAKES SLEEPING DTS HALLUC OTHSYM;
```

ANALYSIS:

```
TYPE IS EFA 1 3;
```

```
output: sampstat;
```

Output from Mplus

SAMPLE STATISTICS

ESTIMATED SAMPLE STATISTICS

SAMPLE THRESHOLDS

| | HANGOVER | NAUSEA\$1 | SWEATS\$1 | SEIZURES | CRAVINGS |
|---|----------|-----------|-----------|----------|----------|
| 1 | -0.153 | 0.446 | 0.507 | 1.912 | 0.044 |

SAMPLE THRESHOLDS

| | PASSOUT\$ | BLACKOUT | SHAKES\$1 | SLEEPING | DTS\$1 |
|---|-----------|----------|-----------|----------|--------|
| 1 | 0.703 | 0.204 | 0.505 | 0.083 | 1.916 |

SAMPLE THRESHOLDS

| | HALLUC\$1 | OTHSYM\$1 |
|---|-----------|-----------|
| 1 | 1.489 | 1.612 |

These are just cumulates of the normal distribution describing the overall marginal proportion of a “NO” response

e.g. $F(-.153) = .439$, Hence the proportion with a hangover is $1 - .439 = .561$
or $F(1.612) = .9465$, Hence the proportion with other symptoms is $1 - .9465 = .0535$

Example association between Hangover and Nausea

| Frequency | | NAUSEA | | | |
|-----------|---------|---------|-------|--------|-------|
| | | 0 | 1 | Total | |
| Percent | Row Pct | Col Pct | 0 | 1 | Total |
| ----- | | | | | |
| | 0 | 3179 | 433 | 3612 | |
| | | 38.64 | 5.26 | 43.90 | |
| | | 88.01 | 11.99 | | |
| | | 57.50 | 16.05 | | |
| HANGOVER | ----- | | | | |
| | 1 | 2350 | 2265 | 4615 | |
| | | 28.56 | 27.53 | 56.10 | |
| | | 50.92 | 49.08 | | |
| | | 42.50 | 83.95 | | |
| ----- | | | | | |
| Total | | 5529 | 2698 | 8227 | |
| | | 67.21 | 32.79 | 100.00 | |

$$\text{odds ratio} = \frac{ad}{bc} = \frac{3179 * 2265}{2350 * 433} = 7.0762$$

The polychoric correlation is estimated by maximum likelihood finding the bivariate correlation needed so that if a bivariate normal were dichotomized using the univariate thresholds that the 2 by 2 table above would result. It is 0.623 (Next page).

Approximation to the polychoric correlation

- Yule's Q = $\frac{or-1}{or+1} = 0.7523$
- Digby's approximation = $\frac{(or)^{3/4}-1}{(or)^{3/4}+1} = 0.6254$

Output from Mplus

SAMPLE TETRACHORIC CORRELATIONS

| | HANGOVER | NAUSEA | SWEATS | SEIZURES | CRAVINGS |
|----------|----------|--------|--------|----------|----------|
| HANGOVER | ----- | ----- | ----- | ----- | ----- |
| NAUSEA | 0.623 | | | | |
| SWEATS | 0.449 | 0.503 | | | |
| SEIZURES | 0.098 | 0.305 | 0.258 | | |
| CRAVINGS | 0.429 | 0.434 | 0.540 | 0.217 | |
| PASSOUT | 0.481 | 0.449 | 0.349 | 0.265 | 0.385 |
| BLACKOUT | 0.539 | 0.483 | 0.364 | 0.240 | 0.385 |
| SHAKES | 0.437 | 0.495 | 0.652 | 0.411 | 0.499 |
| SLEEPING | 0.391 | 0.409 | 0.558 | 0.165 | 0.512 |
| DTS | 0.232 | 0.356 | 0.464 | 0.433 | 0.339 |
| HALLUC | 0.242 | 0.354 | 0.453 | 0.468 | 0.427 |
| OTHSYM | 0.055 | 0.152 | 0.111 | 0.044 | 0.139 |

SAMPLE TETRACHORIC CORRELATIONS

| | PASSOUT | BLACKOUT | SHAKES | SLEEPING | DTS |
|----------|---------|----------|--------|----------|-------|
| BLACKOUT | ----- | ----- | ----- | ----- | ----- |
| SHAKES | 0.449 | 0.482 | | | |
| SLEEPING | 0.304 | 0.335 | 0.505 | | |
| DTS | 0.310 | 0.360 | 0.638 | 0.343 | |
| HALLUC | 0.268 | 0.251 | 0.439 | 0.447 | 0.563 |
| OTHSYM | 0.114 | 0.089 | 0.139 | 0.214 | 0.174 |

SAMPLE TETRACHORIC CORRELATIONS

| | HALLUC | OTHSYM |
|--------|--------|--------|
| OTHSYM | ----- | ----- |
| | 0.162 | |

Output from Mplus - Pearson correlations

| | Correlations | | | | |
|----------|--------------|--------|--------|----------|----------|
| | HANGOVER | NAUSEA | SWEATS | SEIZURES | CRAVINGS |
| | ----- | ----- | ----- | ----- | ----- |
| HANGOVER | 1.000 | | | | |
| NAUSEA | 0.392 | 1.000 | | | |
| SWEATS | 0.273 | 0.322 | 1.000 | | |
| SEIZURES | 0.030 | 0.100 | 0.084 | 1.000 | |
| CRAVINGS | 0.280 | 0.275 | 0.343 | 0.066 | 1.000 |
| PASSOUT | 0.275 | 0.275 | 0.208 | 0.087 | 0.228 |
| BLACKOUT | 0.353 | 0.311 | 0.228 | 0.076 | 0.250 |
| SHAKES | 0.265 | 0.317 | 0.438 | 0.138 | 0.315 |
| SLEEPING | 0.253 | 0.259 | 0.358 | 0.051 | 0.342 |
| DTS | 0.067 | 0.117 | 0.156 | 0.133 | 0.101 |
| HALLUC | 0.096 | 0.156 | 0.205 | 0.171 | 0.173 |
| OTHSYM | 0.021 | 0.059 | 0.043 | 0.009 | 0.054 |

| | Correlations | | | | |
|----------|--------------|----------|--------|----------|-------|
| | PASSOUT | BLACKOUT | SHAKES | SLEEPING | DTS |
| | ----- | ----- | ----- | ----- | ----- |
| PASSOUT | 1.000 | | | | |
| BLACKOUT | 0.434 | 1.000 | | | |
| SHAKES | 0.275 | 0.308 | 1.000 | | |
| SLEEPING | 0.180 | 0.216 | 0.321 | 1.000 | |
| DTS | 0.104 | 0.112 | 0.212 | 0.103 | 1.000 |
| HALLUC | 0.116 | 0.106 | 0.199 | 0.183 | 0.228 |
| OTHSYM | 0.043 | 0.035 | 0.054 | 0.083 | 0.042 |

| | Correlations | |
|--------|--------------|--------|
| | HALLUC | OTHSYM |
| | ----- | ----- |
| HALLUC | 1.000 | |
| OTHSYM | 0.049 | 1.000 |

Output from Mplus - treating data as categorical

RESULTS FOR EXPLORATORY FACTOR ANALYSIS

EIGENVALUES FOR SAMPLE CORRELATION MATRIX

| | 1 | 2 | 3 | 4 | 5 |
|---|-------|-------|-------|-------|-------|
| 1 | 5.186 | 1.366 | 1.063 | 0.932 | 0.644 |

EIGENVALUES FOR SAMPLE CORRELATION MATRIX

| | 6 | 7 | 8 | 9 | 10 |
|---|-------|-------|-------|-------|-------|
| 1 | 0.610 | 0.499 | 0.469 | 0.369 | 0.327 |

EIGENVALUES FOR SAMPLE CORRELATION MATRIX

| | 11 | 12 |
|---|-------|-------|
| 1 | 0.299 | 0.236 |

Output from Mplus - treating data as categorical

ROOT MEAN SQUARE RESIDUAL IS 0.0894
 ESTIMATED FACTOR LOADINGS

| | 1 |
|----------|-------|
| HANGOVER | 0.617 |
| NAUSEA | 0.693 |
| SWEATS | 0.732 |
| SEIZURES | 0.431 |
| CRAVINGS | 0.657 |
| PASSOUT | 0.610 |
| BLACKOUT | 0.639 |
| SHAKES | 0.800 |
| SLEEPING | 0.632 |
| DTS | 0.628 |
| HALLUC | 0.598 |
| OTHSYM | 0.199 |

ROOT MEAN SQUARE RESIDUAL IS 0.0562
 PROMAX ROTATED LOADINGS

| | 1 | 2 |
|----------|--------|--------|
| HANGOVER | 0.856 | -0.130 |
| NAUSEA | 0.604 | 0.176 |
| SWEATS | 0.311 | 0.502 |
| SEIZURES | -0.086 | 0.573 |
| CRAVINGS | 0.375 | 0.353 |
| PASSOUT | 0.671 | 0.025 |
| BLACKOUT | 0.739 | -0.003 |
| SHAKES | 0.282 | 0.608 |
| SLEEPING | 0.289 | 0.412 |
| DTS | -0.064 | 0.785 |
| HALLUC | -0.109 | 0.798 |
| OTHSYM | 0.025 | 0.196 |

Promax factor correlations

| | 1 | 2 |
|---|-------|-------|
| 1 | 1.000 | |
| 2 | 0.589 | 1.000 |

Output from Mplus - treating data as categorical

ROOT MEAN SQUARE RESIDUAL IS 0.0343

PROMAX ROTATED LOADINGS

| | 1 | 2 | 3 |
|----------|--------|--------|--------|
| HANGOVER | 0.553 | -0.232 | 0.405 |
| NAUSEA | 0.401 | 0.047 | 0.373 |
| SWEATS | -0.003 | 0.137 | 0.715 |
| SEIZURES | 0.091 | 0.655 | -0.108 |
| CRAVINGS | 0.104 | 0.053 | 0.595 |
| PASSOUT | 0.754 | 0.114 | -0.059 |
| BLACKOUT | 0.840 | 0.087 | -0.069 |
| SHAKES | 0.180 | 0.396 | 0.405 |
| SLEEPING | -0.056 | 0.024 | 0.748 |
| DTS | 0.022 | 0.679 | 0.159 |
| HALLUC | -0.121 | 0.556 | 0.347 |
| OTHSYM | -0.037 | 0.082 | 0.187 |

PROMAX FACTOR CORRELATIONS

| | 1 | 2 | 3 |
|---|-------|-------|-------|
| 1 | 1.000 | | |
| 2 | 0.371 | 1.000 | |
| 3 | 0.576 | 0.480 | 1.000 |

Response variable approach

For a given response vector \mathbf{x} , we can write its distribution as...

$$p(\mathbf{x}) = \int p(\mathbf{x}, \mathbf{f}) d\mathbf{f} = \int p(\mathbf{x}|\mathbf{f})p(\mathbf{f})d\mathbf{f}$$

We will assume local conditional independence for the elements x_j in \mathbf{x} given \mathbf{f} , so that

$$p(\mathbf{x}|\mathbf{f}) = \prod_{j=1}^p p(x_j|\mathbf{f})$$

We first consider the binary case where each element in \mathbf{x} is equal to 0 or 1. We assume the underlying factors \mathbf{f} are $N(0, I)$. A natural function/distribution to choose for $p(x_j|\mathbf{f})$ is the logistic function,

$$p(x_j|\mathbf{f}) = \pi_j(\mathbf{f}) = \frac{\exp(\alpha_{0j} + \boldsymbol{\alpha}'_{1j}\mathbf{f})}{1 + \exp(\alpha_{0j} + \boldsymbol{\alpha}'_{1j}\mathbf{f})}$$

where α_{0j} is the intercept or “difficulty” of item j , and the vector $\boldsymbol{\alpha}_{1j}$ represent the slopes relating each of the k factors to item j , these are also called the “discrimination” parameters. When there is only one factor, the $\boldsymbol{\alpha}_{1j}$ becomes a single scalar α_{1j} .

Response variable approach

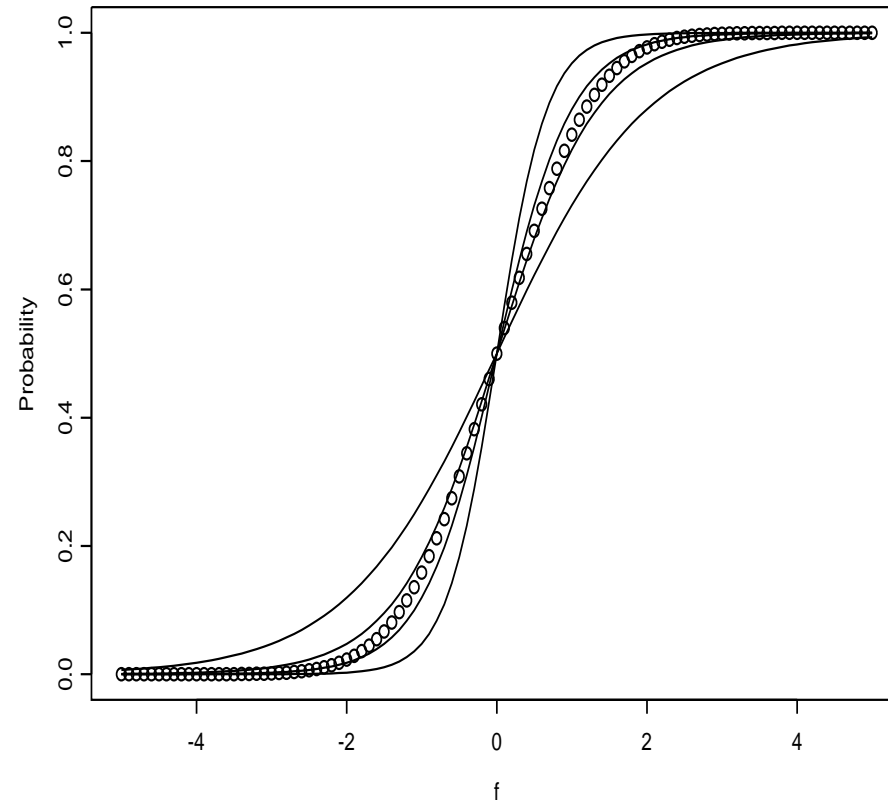

Other link functions besides the logistic can be used, e.g. the normal ogive. The dots represent the normal ogive (i.e. the cumulative distribution of the $N(0,1)$ distribution). The lines represent the logit function with $\alpha_0 = 0$ and $\alpha_1 = 1, 1.5, 2, 3$, respectively.

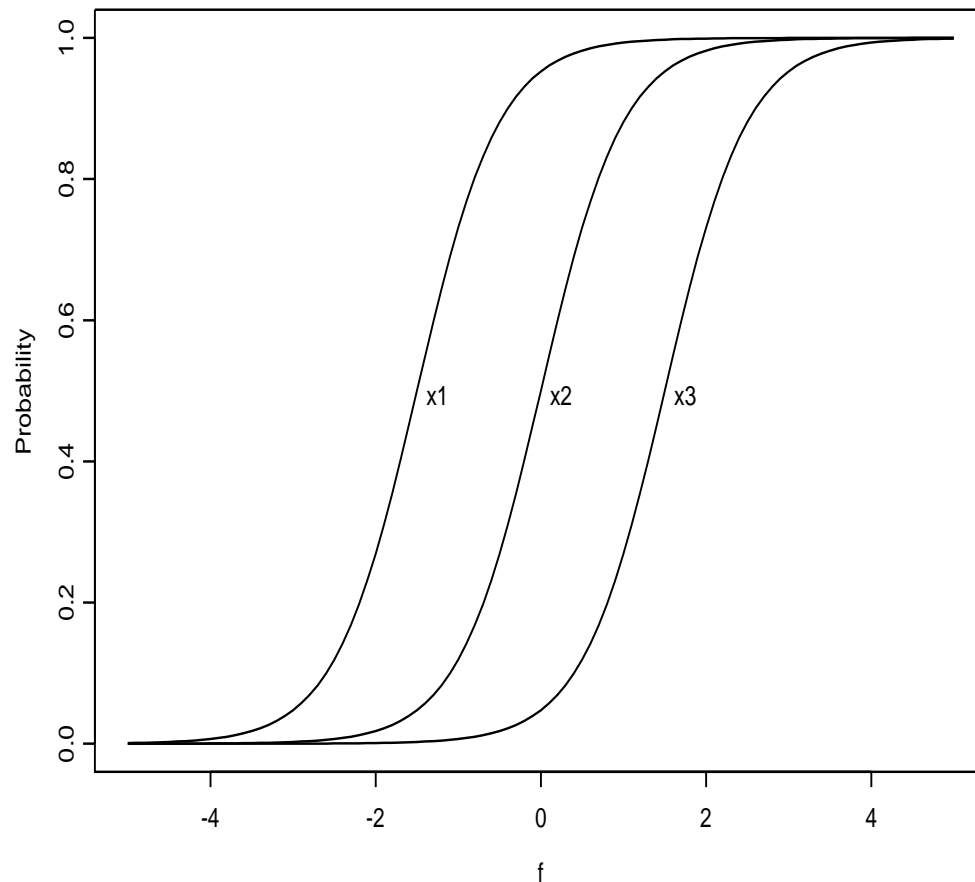

Rasch model. The $\alpha_{11} = \alpha_{12} = \alpha_{13}$ (i.e. the slopes “discriminations” are the same), but the intercepts “difficulties” vary $\alpha_{01} = 3$, $\alpha_{02} = 0$, $\alpha_{03} = -3$

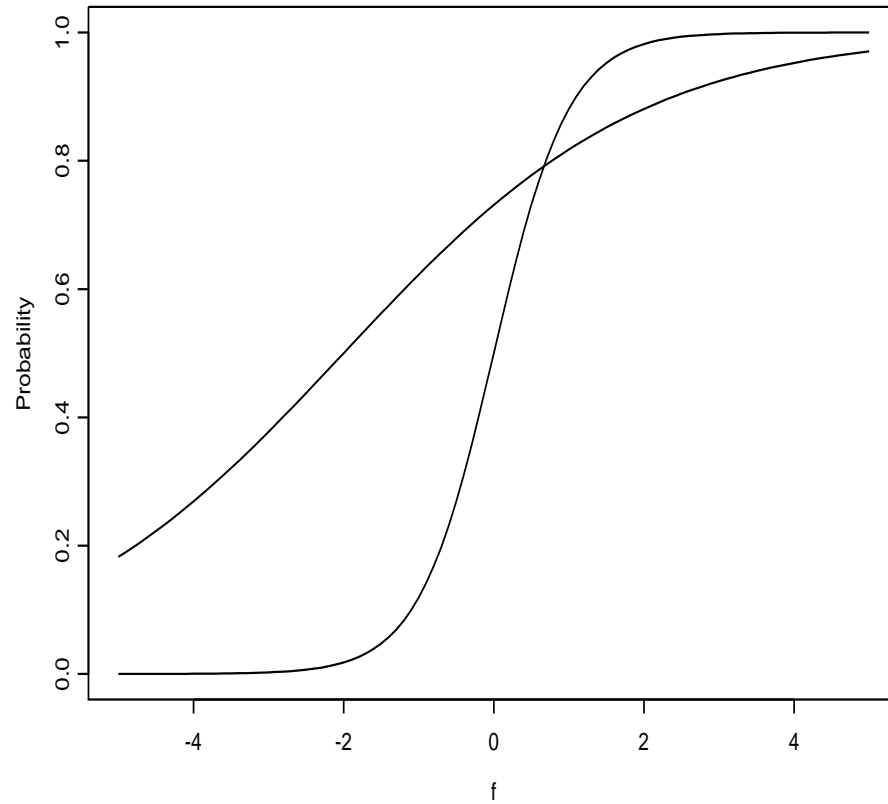

Here the two observed variables have different slopes and intercepts.

$$\alpha_{01} = 0 \text{ and } \alpha_{11} = 2$$

$$\alpha_{01} = 1 \text{ and } \alpha_{11} = .5$$

Ability of the items to discriminate individuals on the latent factor differs throughout

Response variable approach - more than two category outcomes

Similar idea, use the cumulative odds model.

Pros and cons of the two approaches

Software:

- The underlying variable approach is implemented in Mplus and LISREL (not AMOS). Very simply (in Mplus), the user specifies which observed variables are categorical and the software implements the method.
- The response variable approach is not available in LISREL or AMOS. It is NEWLY available in Mplus version 4 using the estimator = MLR statement. It can be programmed directly (writing down the likelihood) in Proc NLMIXED or within a Bayesian framework using Winbugs. An add-on to STATA called gllam ("generalized linear latent variable modeling") will do this approach. Specialized softwares exist within developed by researchers in the education field for using this approach.

The following are points taken from "Factor analysis of ordinal variables: A comparison of three Approaches" by Karl Jöreskog and Irini Moustaki *Multivariate Behavioral Research*, 36(3), 347-387, 2001.

- In theory, the response function approach is better than the underlying variable approach, but from a practical point of view their use is limited.
- The Response function approach are computationally heavy. The likelihood is not available in closed form and is approximated by numerical integration requiring several quadrature points. They work reasonably well for 1 and 2 factors. Eg, NLMIXED does not recommend fitting models with more than two "random effects", that is underlying factors. If an accurate solution is not required, it is possible to handle three and four factors by reducing the number of quadrature points along each dimension.
- By contrast, the underlying variable approach (using bivariate moments) is feasible for many variables and many factors. One particular advantage is that computer time does not increase with sample size.

Goals:

- If the goal is a factor analysis with many factors in particular to identify clusters of variable "measuring" the same things, then there is no choice but to use the UV approach.
- If on the other hand the goal is to find/choose a set of items measuring only one factor and then to use these items to specifically score and rank individuals, the response theory approach is appropriate.

The connection between IRT and Underlying variable approach

Takane and de Leeuw (1987, *Psychometrika*) showed that a discrete measurement model of the underlying variable form is equivalent to the IRT model when a normal CDF (a normal ogive) is used to describe the link between the underlying factors and the observed variables. For the underlying variable model with $\mathbf{x}^* = \boldsymbol{\mu} + \boldsymbol{\Lambda}\mathbf{f} + \boldsymbol{\epsilon}$, with $Var\boldsymbol{\epsilon} = \boldsymbol{\Psi}$, they showed that the IRT parameters α_{0j} and α_{1j} can be expressed in terms of the parameters of the underlying variable model as

$$\alpha_{1j} = \frac{\lambda'_j}{\sqrt{\psi_j}} \quad \text{and} \quad \alpha_{0j} = \frac{-\tau_j}{\sqrt{\psi_j}}$$

So, in fact no fundamental difference between the methods, boils down to how the parameters are estimated.